

## PC-14

## Curved Classical Swing

- Curved SDM pipes with a diameter of 114 mm are connected with doetail metal clamps with a wall thickness of at least 3 mm
- The open parts of the 114 mm diameter SDM pipes are detailed to prevent rusting caused by water and moisture, shaped with hemispherical injection molds, closed with self-colored plastic plugs and riveted.
- In order to close the open-ended pipes; anchor covers made of double-walled self-colored polyethylene plastic material LLDPE (Linear Low Density Polyethylene) are used.
- Inclined classical swing is created by using 4 swing side struts, a minimum 2.5 m 114 mm inclined pipe, 1 3 m Ø 114 mm intermediate pipe and 2 protected polyethylene seat products.
- The flat seat is designed to wrap the user's body and is made of LLDPE (Linear Low Density Polyethylene), a self-colored polyethylene plastic material weighing at least 2.5 kg.
- The swing seat railing is manufactured by LLDPE (Linear Low Density Polyethylene) blow molding manufacturing method from self-colored polyethylene plastic material weighing at least 0.5 kg.
- The chain channels through which the chain must pass are manufactured ready to use on the product.
- The swing chains are at least 6 mm thickness and coated with galvanized 25 micron hot-dip.
- The chains are connected in a double row on the polyethylene protected seat.
- The chains are connected by chain locks to the bearing wedges, which are welded together on the swing carrier.
- In order to prevent the chain locks from being easily removed, the bolt is manufactured with an allen head and galvanized coated for corrosion resistance.
- The length of the main chain is 175 cm long, and a 6 mm caliber dipped chain is used.
- Double Swing chains are manufactured in such a way as to prevent finger jamming of small children and babies.
- The distance between the bottom of the polyethylene swing seat and the ground is a maximum of 40 cm.

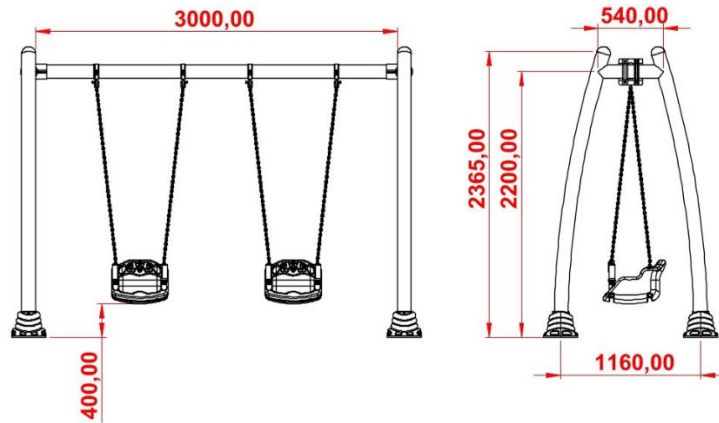

<b>Dimensions</b>	Side Pipe Length	250 cm
	Horizontal Pipe Length	300 cm
	Swing Seat Width	44 cm
	Swing Seat Length	32 cm
	Swing Seat Height	33 cm
	Minimum Swing Seat Weight	2,5 kg
	Minimum Weight of Swing Railing	0,5 kg
	Chain Length	175 cm
	Chain Thickness	6 mm

