

PT-132



Age range
5+



Number of
Users
15-20



Free Fall
Height
2,8 m



Height
5,58 m



Assemble
Area
65 m²



Sitting Area
4,75m*13,58m



Safety Area
7,25*16,58m

PRODUCT TREE

HOUSE ROOF	2	Piece
CHONICAL ROOF	1	Piece
H:100 WAVY SLIDE	1	Piece
H:100 DOUBLE SLIDE	1	Piece
H:150 SPIRAL SLIDE	1	Piece
180 CM SPIRAL INNER PIPE	1	Piece
HAT FIGURED SLIDE ENTRY	1	Piece
SPIRAL SLIDE ENTRY	1	Piece
BUGS BUNNY SLIDE ENTRY	3	Piece
FENCE PANEL	2	Piece
DUCK FIGURED PANEL	2	Piece
H:135 STAIRS FROM TOWER TO TOWER	2	Piece
H:135 STAIR RAILS FROM TOWER TO TOWER	2	Set
CAT PANEL WITH BELL JAR	4	Piece
WOODPECKER FIGURE	1	Piece
ROCK CLIMBING	2	Piece
ROCK CLIMBING METAL RAILING	2	Set
H:285 SPIRAL SLIDE WITH TRANSPARENT TUBE	2	Piece
PLASTIC CLAMP WITH STRAIGHT CONNECTION PART	56	Piece
ANCHORAGE COVER	12	Set
116 x 116 SQUARE PLATFORM	5	Piece
60 x 90 SPIRAL SLIDE PLATFORM	1	Piece
SPIRAL SLIDE METAL RAILING	1	Set
SCREW HIDING	30	Piece
H:150 STAIRS FROM GROUND TO TOWER	1	Piece
H:150 STAIR RAILS FROM GROUND TO TOWER	1	Set
Ø27 PANEL INNER PIPE	17	Piece
335 CM TOWER PIPE	4	Piece
470 CM TOWER PIPE	8	Piece

TECHNICAL DRAWING

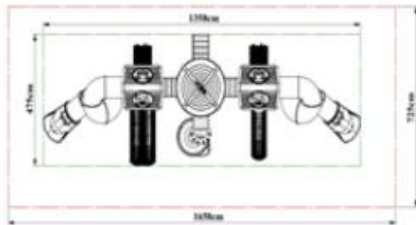
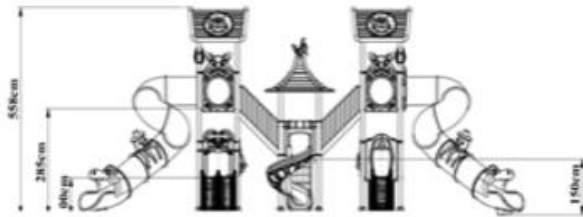

Load-bearing Construction

- Tower, slide, roof, ladder, railing, etc. The main columns that will carry the playgroup elements are manufactured from industrial pipes with a diameter of 114 mm and a wall thickness of min. 2 mm.
- The open top parts of the 114 mm diameter industrial pipes are closed and riveted with self-colored plastic pipe plugs shaped with injection molds in the form of a hemisphere with a wall thickness of 4-6 mm, detailed to prevent corrosion caused by water and moisture.

Polyethylene Products

- The raw material of polyethylene materials to be used in playgrounds is low density linear polyethylene.
- Original raw materials that do not contain any chemicals that may harm children's health and that have EN 1176-1.3 certificate are used.
- In order to prevent electrification, an anti-static agent is added to the polyethylene.
- There is no zinc in the paints used in the polyethylene raw material and the light sensitivity is between 6-8 scales.
- In polyethylene materials, the thickness is at least 5 mm in areas where there is friction and pressure.

Electrostatic Paint

- After all metal parts are manufactured, they are immersed in an iron phosphate bath with 1% concentration at 50 degrees for 15 minutes after rinsing in the dust and degreasing bath with 5% concentration at 70 degrees for 10 minutes.
- Afterward, it is rinsed with clean water again and drying processes are carried out.
- Before the static paint process, sanding is applied in a way to prevent rusting, which may be caused by dust and particles that can settle on the metal parts as a result of air circulation during the drying phase during the resting period.
- After this stage, the material is covered with polyester-based powder paint with a thickness of 60-80 microns, which prevents heating (color fading) in the sun, and then it is heated in an oven at a temperature of at least 200-220 degrees for 10 minutes, and the painting process is completed.

Pipes

- Tower pipes; It is manufactured from SDM pipe with a height of 335 cm, 470 cm a diameter of 114 mm, and a wall thickness of min. 2 mm.
- The tower pipes are produced in one piece and perfectly, from horizontal and vertical pipes in length cut according to the determined heights, with a minimum of 2250 mm.
- Pipes with seam marks on the surface are not used in production.
- Adding the length of the pipes, welding, etc. is not extended by the procedure.
- In order to prevent water, moisture, and foreign matter from entering the upper parts of these pipes, colored plastic pipe plugs produced by the injection method are fixed and closed to the pipes with a riveting system.
- The connection points of the pipes with the concrete floor are joined by the sheet metal flange welding method with the size of 20*20*6 mm.
- Connection of the Tower Pipes with the platform the half-moon-shaped ears welded according to the platform size, produced from 6 mm wall thickness, are welded to the pipes and these ears are connected to the platform with the screwing system by means of galvanized bolts and nuts.
- A polyester-based electrostatic powder paint coating process is performed and it is baked in a 200°C oven for 20 minutes.
- Tower pipes are closed with anchor caps produced by injection after assembly.
- 100 cm high, Ø27 elektrostatic panel inner pipe is used.



Dimensions	Diameter	114 mm
	Wall Thickness	Min. 2 mm

116x116 Square Platform

- The platform is manufactured from perforated sheet metal with a minimum size of 116 cm x 116 cm x 8 cm and a minimum wall thickness of 1.5 mm-2 mm.
- Flat designed surface; It is designed to prevent slipping and not allow water retention.
- In the middle of the platform, support sheets are welded to the lower part in order to prevent the sheet from flexing.
- The corners of the platform are manufactured in the form of a quarter circle, enclosing the 114 mm pipe.
- Before the coating process, the sheets are washed with special chemicals, cleared of oil and dirt that will prevent the coating on them, and then coated with the priming method.
- After the priming process, the upper surface of the platform is hot-dip method with an anti-static material mixture with a hardness of -60 ± 5 share A, a density of 1 gr/cm³, minimum kgf/cm² breaking strength, 650-700% breaking elongation, and 100 m³ (max) abrasion. PVC (Plastisol) coating is made.
- PVC thickness is produced at a minimum of 2 mm at each point.

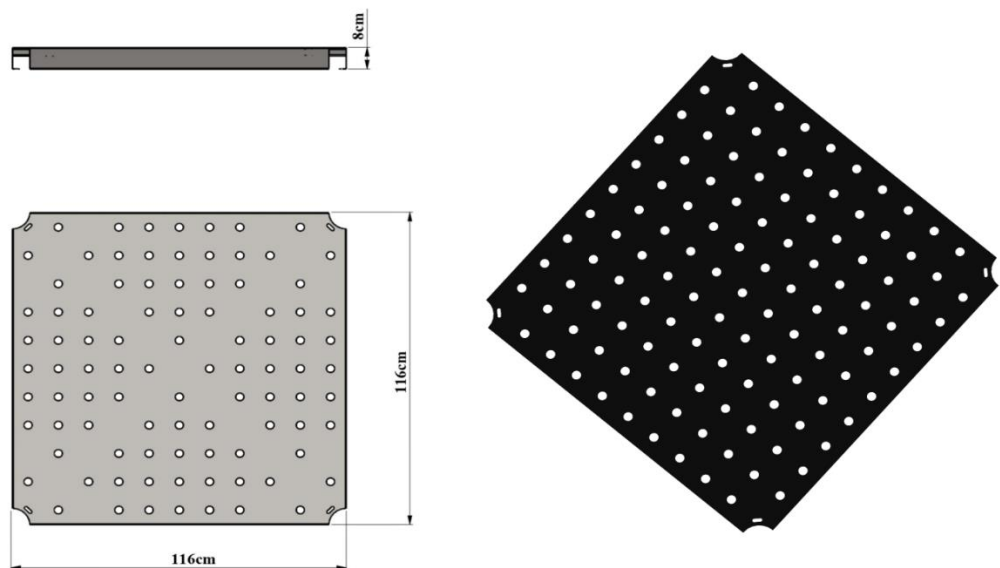

Dimensions	Platform Dimensions	116*116 cm
	Sheet Thickness	2 mm - 8 cm
Features	Plastisol Coated Platform	

60x90 Spiral Extension Platform

- The platform is manufactured from perforated sheet metal with a minimum dimension of 60 cm x 90 cm x 8 cm and a minimum wall thickness of 1.5 mm-2 mm.
- Flat designed surface; It is designed to prevent slipping and not allow water retention.
- In the middle of the platform, support sheets are welded to the lower part in order to prevent the sheet from flexing.
- The corners of the platform are manufactured in the form of a quarter circle, enclosing the 114 mm pipe.
- Before the coating process, the sheets are washed with special chemicals, cleared of oil and dirt that will prevent the coating on them, and then coated with the priming method.
- After the priming process, the upper surface of the platform is hot-dip method with an anti-static material mixture with a hardness of -60 ± 5 share A, a density of 1 gr/cm³, minimum kgf/cm² breaking strength, 650-700% breaking elongation, and 100 m³ (max) abrasion. PVC (Plastisol) coating is made.
- PVC thickness is produced at a minimum of 2 mm at each point.
- The platform is attached to the square platform by screwing and its assembly is provided.

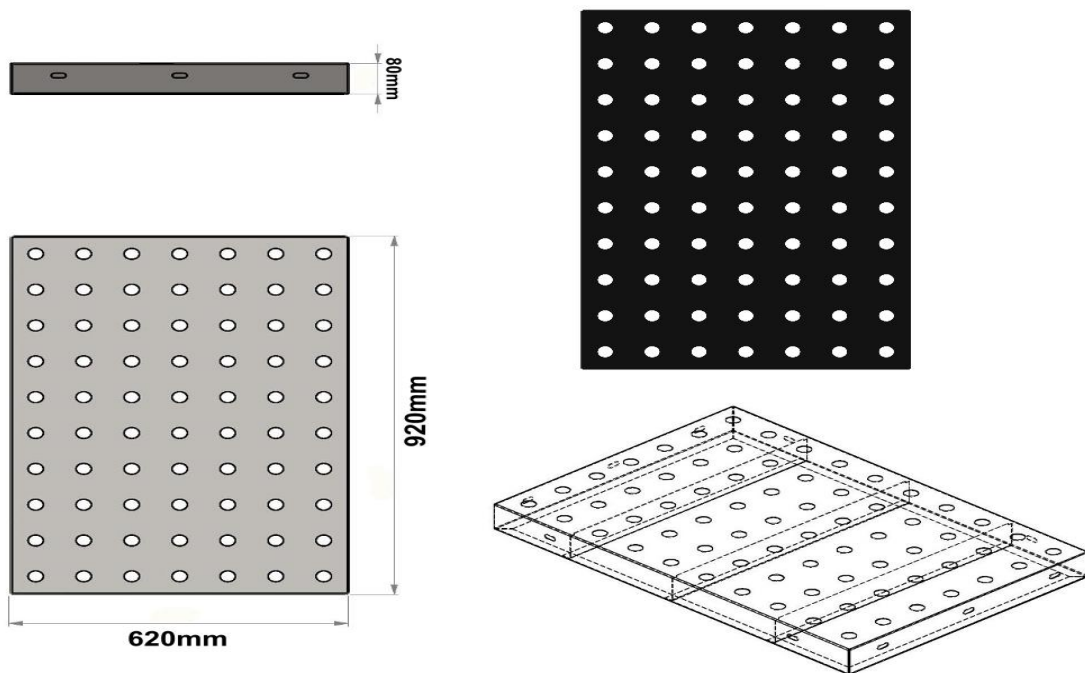

Dimensions	Platform Dimensions	60*90 cm
	Sheet Thickness	2 mm - 8 cm
Features	Plastisol Coated Platform	

Spiral Slide Metal Railing

- The edges of the stair railing are produced from a maximum of $\text{Ø } 27 \text{ mm}$ pipe, and the railings are produced from a minimum of $\text{Ø } 21 \text{ mm}$ pipes.
- Stair railings are painted with polyester-based electrostatic powder paint.
- The slide entrance railing is produced as a single piece of metal.
- The slide entry guardrail is connected to the carrier pole with the help of polyamide clamps with $\text{Ø}27 \text{ mm}$ pipes from the top.
- It is mounted on the platform with the help of galvanized bolts and nuts from the bottom.

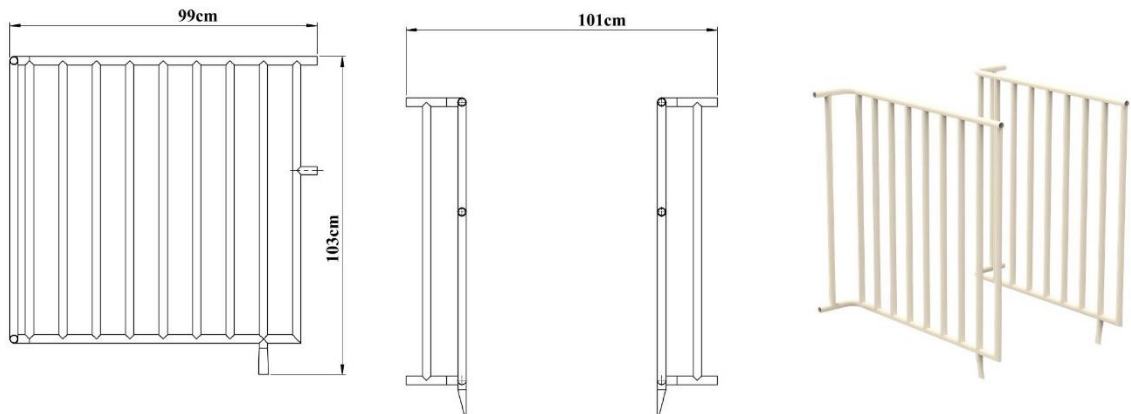

Dimensions	Outer Frame Tube	$\text{Ø } 27 \text{ mm}$
	Frame Inner Tube	$\text{Ø } 21 \text{ mm}$
	Minimum Distance Between Railings	88 mm

H:135 Tower To Tower Stair Rail

- The edges of the stair railing are made of a maximum of $\text{Ø } 27 \text{ mm}$ pipes, and the railings are made of a minimum of $\text{Ø } 21 \text{ mm}$ pipes.
- The distance between the handrails on the stair railing from the platform to the platform is a minimum of 89 mm.
- Stair railings are painted with polyester-based electrostatic powder paint.

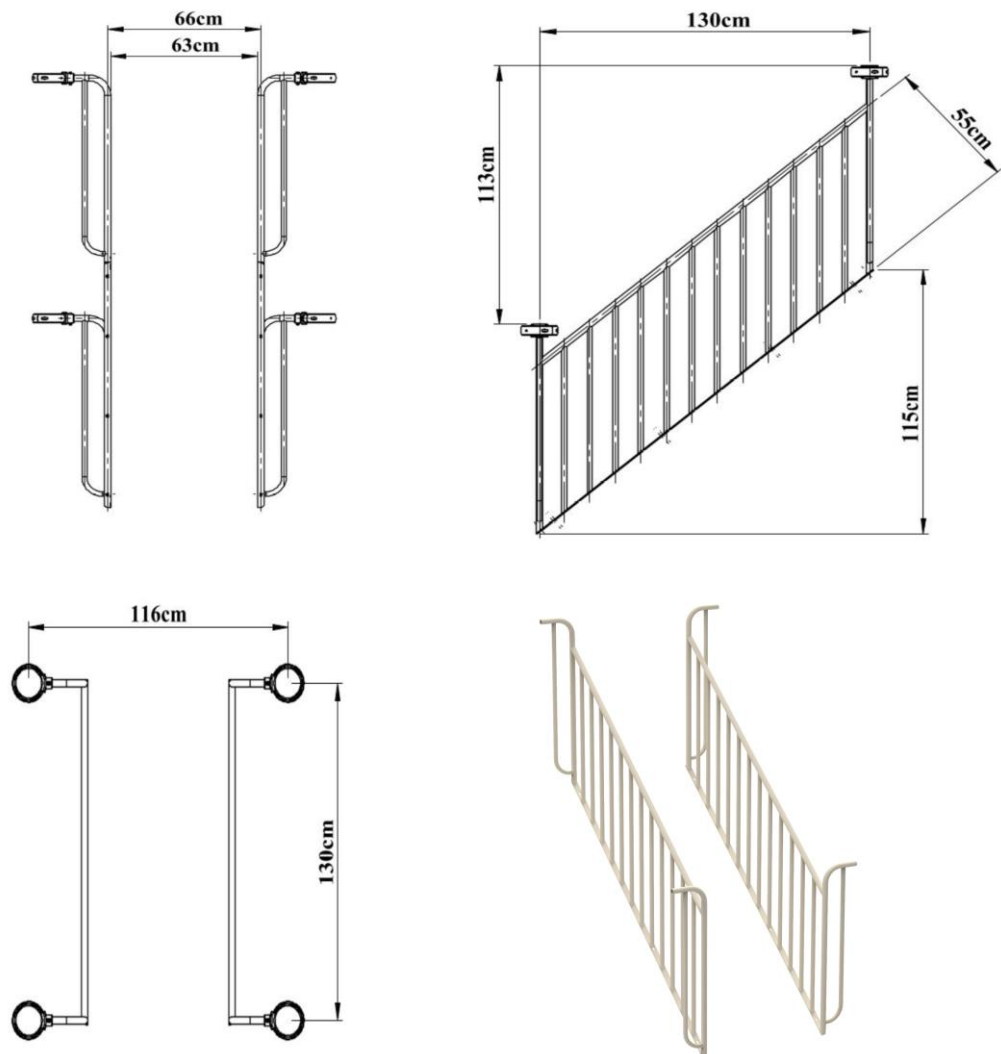

Dimensions	Outer Frame Tube	$\text{Ø } 27 \text{ mm}$
	Frame Inner Tube	$\text{Ø } 21 \text{ mm}$

H: 150 Cm Ground to Tower Stair Railing

- The edges of the stair railing are made of a maximum of $\text{Ø } 27 \text{ mm}$ pipes, and the railings are made of a minimum of $\text{Ø } 21 \text{ mm}$ pipes.
- The distance between the handrails on the stair railing from the platform to the platform is a minimum of 89 mm.
- Stair railings are painted with polyester-based electrostatic powder paint.

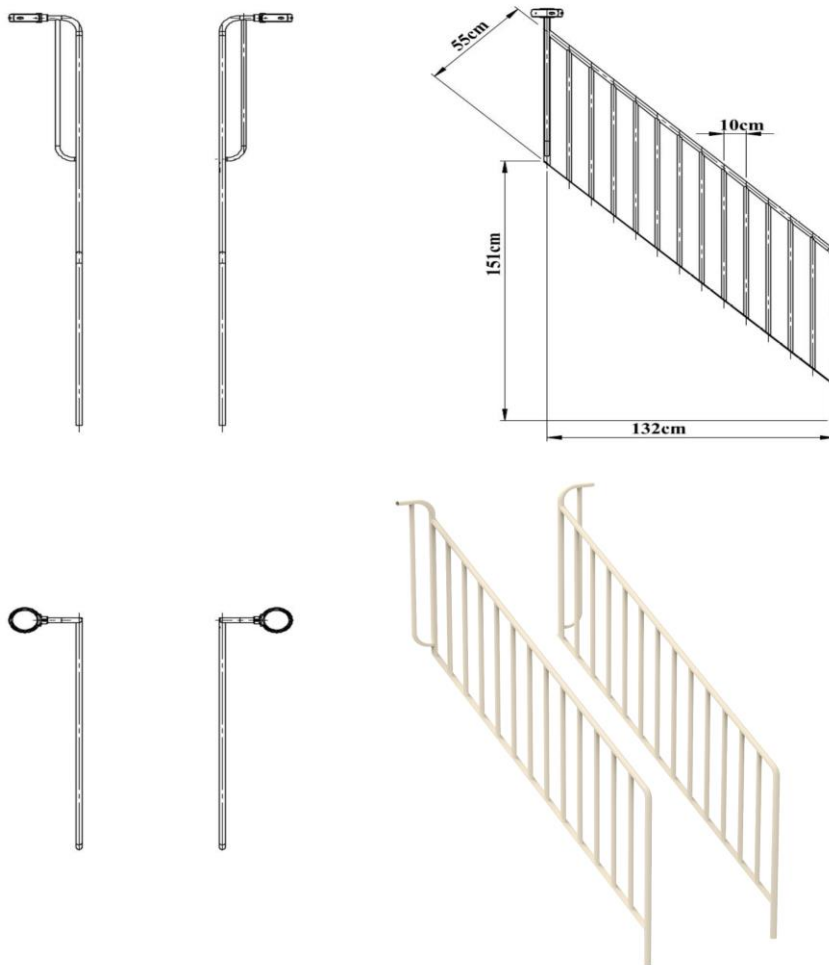

Dimensions	Outer Frame Tube	$\text{Ø } 27 \text{ mm}$
	Frame Inner Tube	$\text{Ø } 21 \text{ mm}$
	Minimum Distance Between Railings	89 mm

H:135 Tower To Tower Ladder

- Ladders are manufactured in one piece, with a minimum of 6 steps, from the tower to the platform, with a height difference of 135 cm.
- The step height of the stairs is produced with a minimum of 130 mm and a maximum of 200 mm.
- The steps are manufactured from dkp sheet with a minimum wall thickness of 1.5 mm - 2 mm.
- There will be no sharp or sharp edges, corners, or points on the stairs, and no shapes that may cause injury will be used in any way whatsoever.
- Unlike the ladder from the ground to the tower, it is mounted on both sides to be screwed to two platforms.
- Stair treads are mixed -60 ± 5 share A hardness, 1 gr/cm^3 density, minimum kgf/cm^2 breaking strength, 650-700% breaking elongation and 100 m^3 (max) wear feature, anti-static material mixed with PVC (Plastisol) method by hot dipping method.) will be covered. PVC thickness is at least 2 mm at each point.

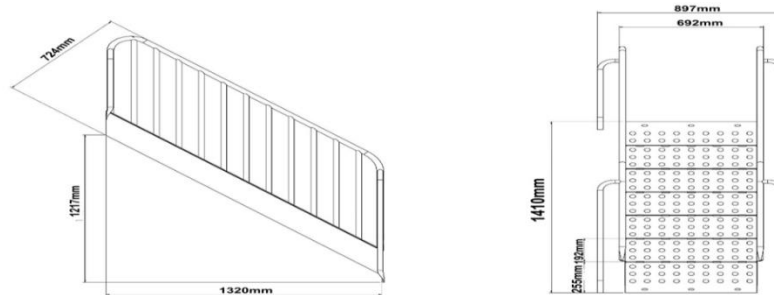

Dimensions	Platform Height	135 cm
	Sheet Thickness	2 mm-1,5 mm
Features	Plastic Coated Stairs + Metal Railing	

H: 150 Cm Ground to Tower Ladder

- Ladders are manufactured in one piece with a minimum of 7 steps, with a height difference of 150 cm from the ground to the platform.
- The step height of the stairs is produced with a minimum of 130 mm and a maximum of 200 mm.
- The steps are manufactured from dkp sheet with a minimum wall thickness of 1.5 mm - 2 mm.
- There will be no sharp or sharp edges, corners, or points on the stairs, and no shapes that may cause injury will be used in any way whatsoever.
- Stair treads are mixed -60 ± 5 share A hardness, 1 gr/cm^3 density, minimum kgf/cm^2 breaking strength, 650-700% breaking elongation and 100 m^3 (max) wear feature, anti-static material mixed with PVC (Plastisol) method by hot dipping method.) will be covered. PVC thickness is at least 2 mm at each point.

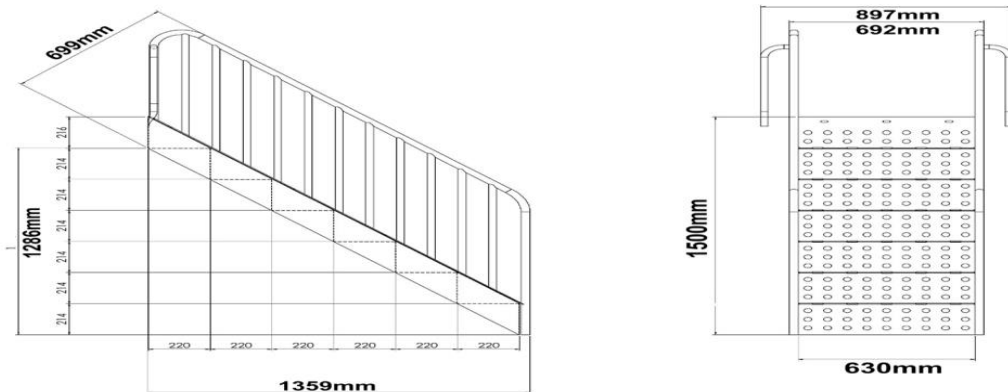

Dimensions	Platform Height	150 cm
	Sheet Thickness	2 mm-1,5 mm
Features	Plastic Coated Stairs + Metal Railing	

Flat Slide Entrance With Hat

- It is manufactured from self-colored polyethylene plastic material as a one-piece and double-walled by rotation molding method with low density (LLDPE Linear Low-Density Polyethylene) designed to prevent falling into the slide entrances.
- Plastic clamps and vertical mouth connection apparatuses are attached to the $\text{Ø } 27 \text{ mm}$ inner pipe ends attached to the slides, and the $\text{Ø } 114 \text{ mm}$ tower is fixed to the pipes and screwed from the parts of the panels that sit on the platform.
- In order for the product surface to be smooth; It is produced by sandblasting the surface of the mold made of aluminum or its equivalent material and undergoing a Teflon coating process for surface brightness.

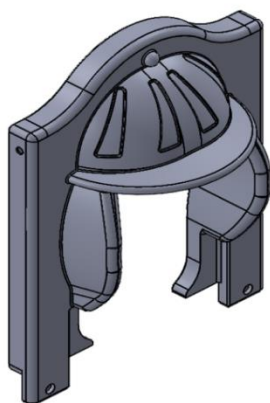
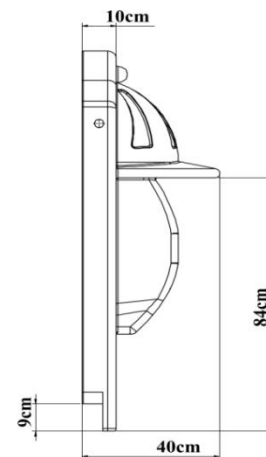
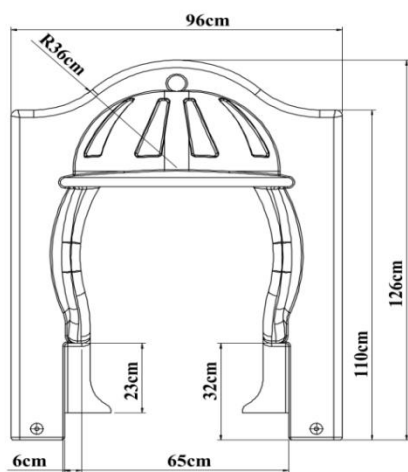

Dimensions	Height	126 cm
	Width	96 cm
	Panel thickness	40 cm
Features	Min Weight	8 kg
	Raw material	LLDPE

Bugs Bunny Slide Entry

- Bugs Bunny Slide Entry are manufactured from self-colored polyethylene LLDPE (Linear Low-Density Polyethylene) material as double-walled by rotation molding method.
- Bugs Bunny Slide Entry are fixed to the main construction with the help of a polyamide-based clamp system with galvanized pipes of 67*93 cm dimensions, Ø 27 mm diameter from the top, and 2 mm wall thickness.
- The dyestuffs used in coloring are suitable for child health.

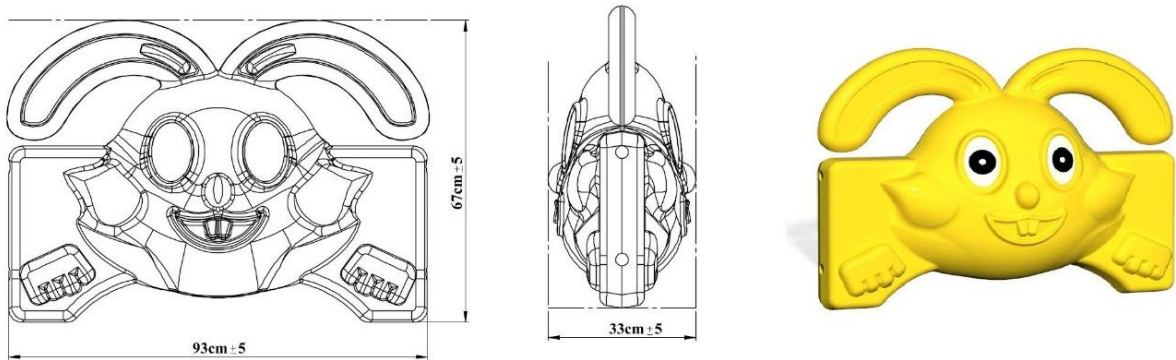

Dimensions	Height	67 cm
	Width	93 cm
	Panel thickness	33 cm
Features	Min Weight	4,5 kg
	Raw material	LLDPE

Spiral Slide Entrance

- It is manufactured from self-colored polyethylene plastic material as a one-piece and double-walled by rotation molding method with low density (LLDPE Linear Low-Density Polyethylene) designed to prevent falling into the slide entrances.
- In order for the product surface to be smooth; It is produced by sandblasting the surface of the mold made of aluminum or its equivalent material and undergoing a Teflon coating process for surface brightness.

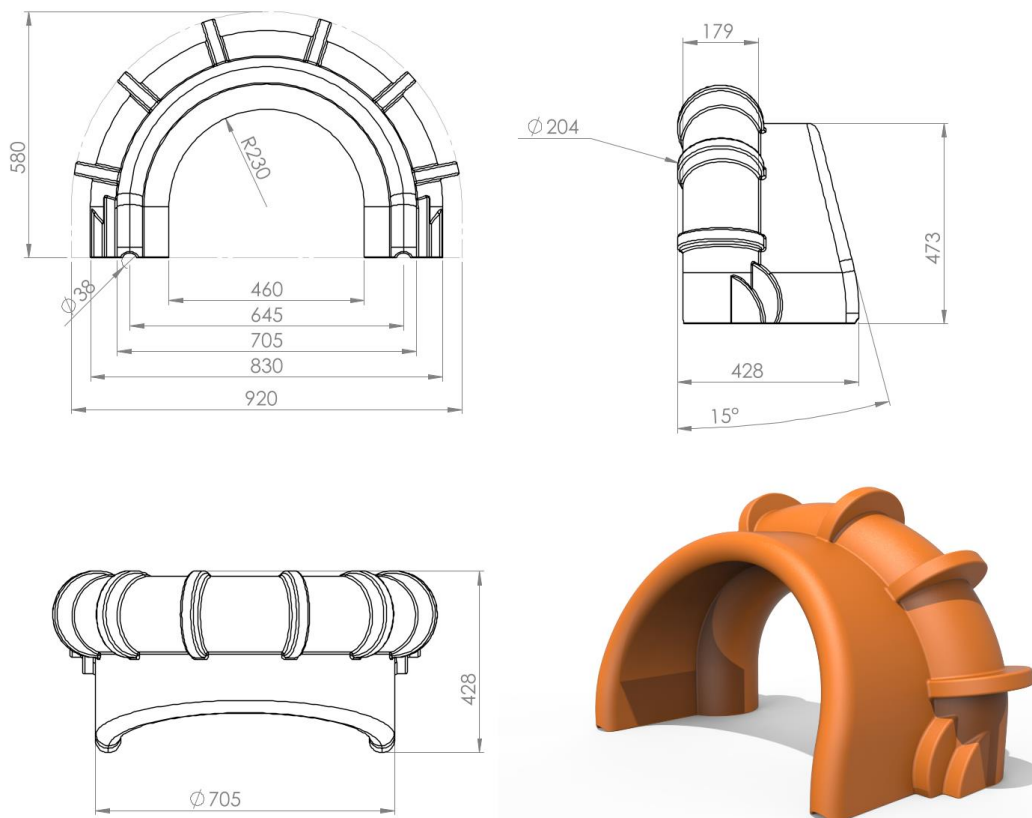

Dimensions	Length	58 cm
	Width	92 cm
	Input Width	46 cm
Features	Min. Weight	8 kg
	Raw material	LLDPE

Fence Panel

- Fence panel are manufactured from self-colored polyethylene LLDPE (Linear Low-Density Polyethylene) material as double-walled by rotation molding method.
- The fence panels are fixed to the main construction with the help of a polyamide-based clamp system with pipes of 90x110 cm dimensions, Ø 27 mm diameter from the top The dyestuffs used in coloring are suitable for child health.

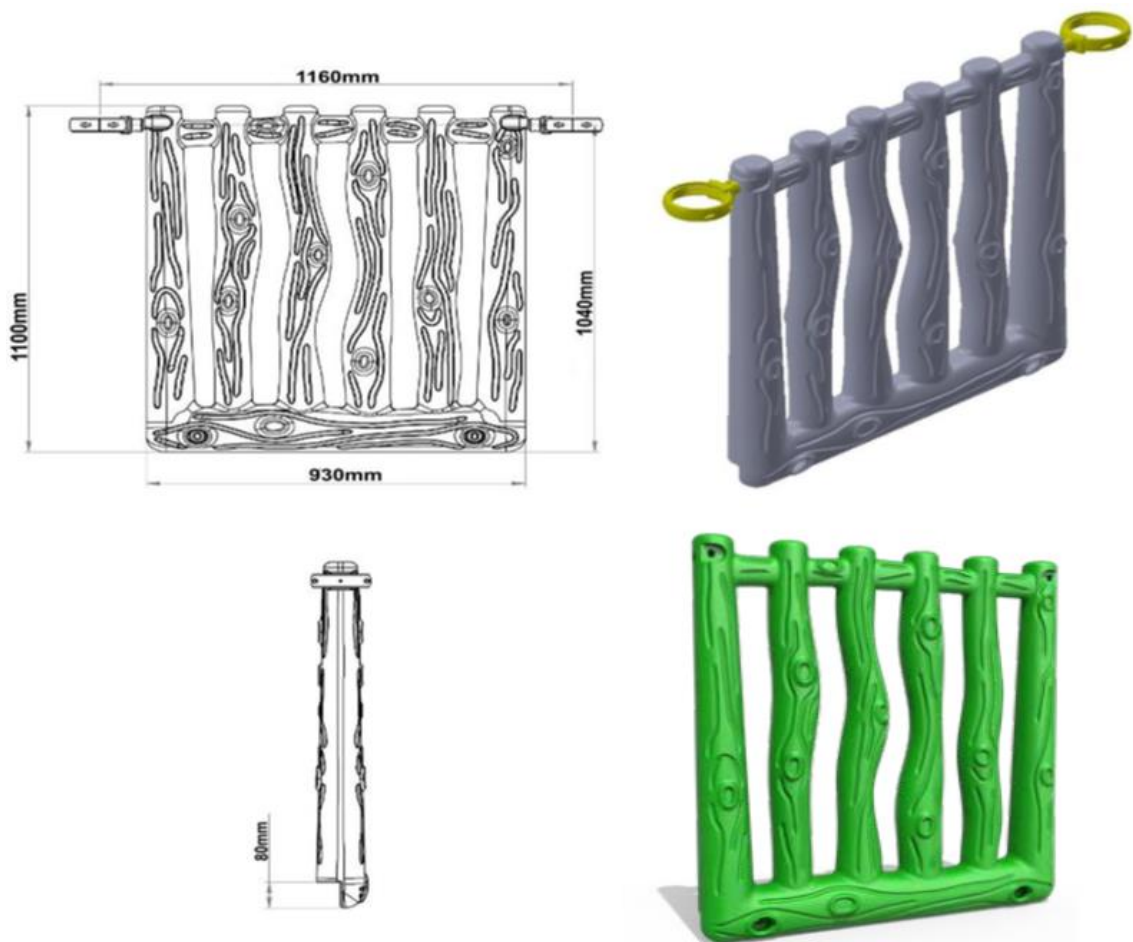

Dimensions	Height	110 cm
	Width	90 cm
	Panel thickness	7 cm
Features	Min Weight	8 kg
	Raw material	LLDPE

Cat Panel With Bell Jar

- Cat Panel With Bell Jar are manufactured from self-colored polyethylene LLDPE (Linear Low-Density Polyethylene) material as double-walled by rotation molding method.
- The Cat Panel With Bell Jar are fixed to the main construction with the help of a polyamide-based clamp system with pipes of 94*159 cm dimensions, Ø 27 mm diameter from the top.
- The dyestuffs used in coloring are suitable for child health.

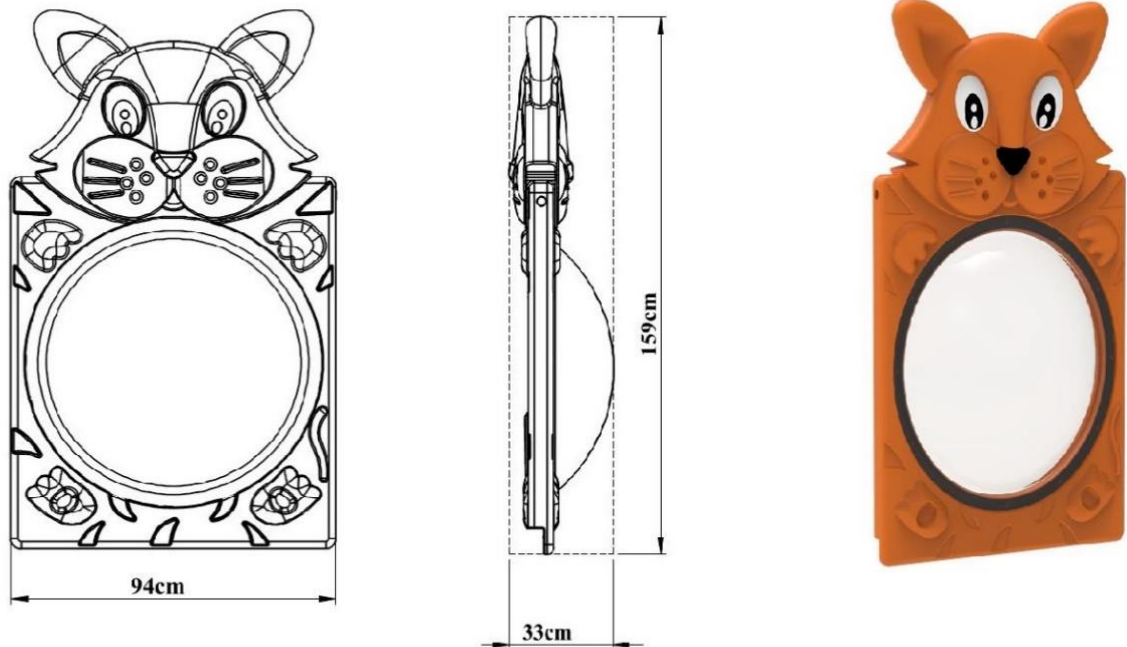

Dimensions	Height	159 cm
	Width	94 cm
	Panel thickness	33 cm
Features	Min Weight	14 kg
	Raw material	LLDPE

Duck Figured Panel

- Duck figured panels are manufactured from self-colored polyethylene LLDPE (Linear Low-Density Polyethylene) material as double-walled by rotation molding method.
- The Duck figured panels are fixed to the main construction with the help of a polyamide-based clamp system with pipes of 95x122 cm dimensions Ø, 27 mm diameter from the top.
- The dyestuffs used in coloring are suitable for child health.

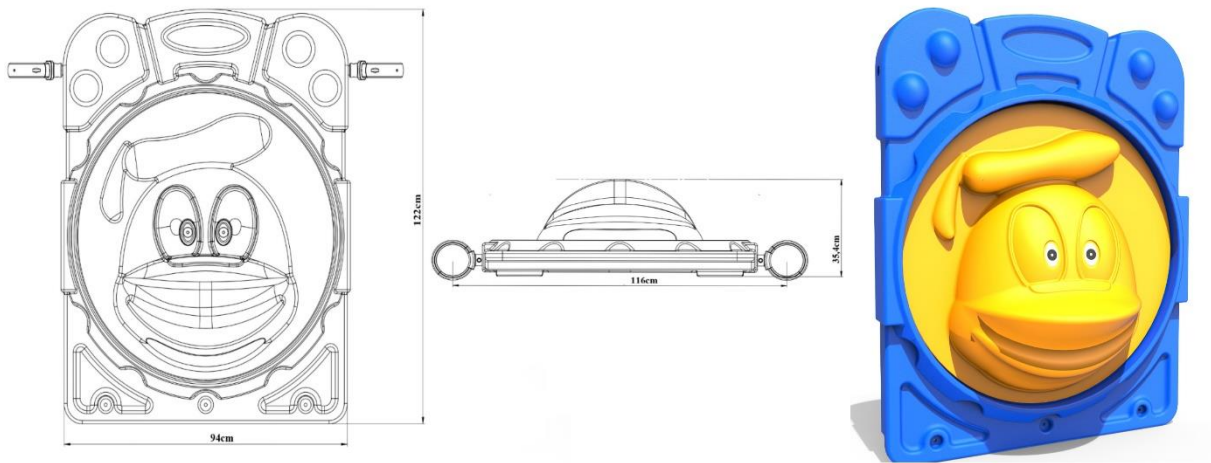

Dimensions	Height	122 cm
	Width	95 cm
	Panel thickness	35,4 cm
Features	Min Weight	12,5 kg
	Raw material	LLDPE

H:100 Wavy Slide

- On the wavy slides connected to the 100 mm high platform; It is manufactured as a single-piece and double-walled LLDPE (Linear Low Density Polyethylene) rotation molding method from self-colored polyethylene plastic material, so that the inclination angle of the slide section with the horizontal does not exceed 60 degrees at any point and 40 degrees on average when the measurement is made according to the longitudinal axis of the slide.
- The slide is fixed to the ground with a metal apparatus from the anchorage point at the bottom of the slide's exit point.
- In order for the product surface to be smooth; Sandblasting is applied to the surface of the mold made of aluminum or its equivalent material, and it is produced by passing the Teflon coating process for surface brightness.
- A flat slide entrance panel is used to ensure safety at the slide entrance.
- LLDPE (Linear Low-Density Polyethylene) from self-colored polyethylene plastic material is produced in one piece by rotation molding method.
- Plastic clamps and vertical mouth connection apparatuses are attached to the $\varnothing 27$ mm inner pipe ends attached to the inside of the polyethylene flat slide entrance panels and fixed to the $\varnothing 114$ mm tower pipes.

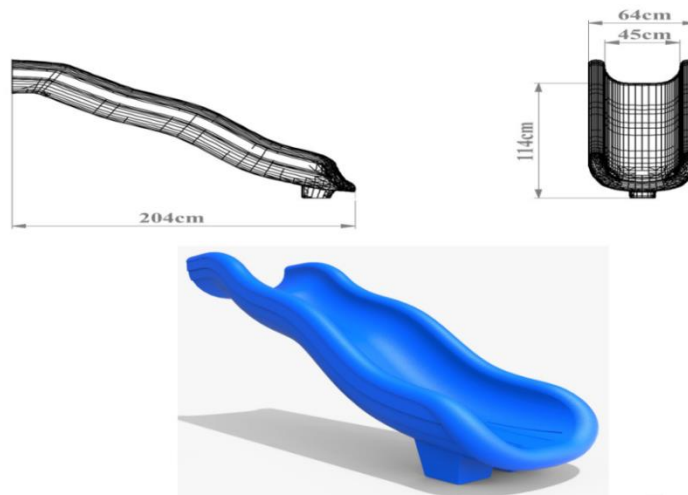

Dimensions	Platform Height	100 cm
	Side Wall Length	17 cm
	Slide Inner Width	40 cm
	Slide Length	210 cm
Features	Raw material	LLDPE
	Min. Slide Weight	24 kg

H:100 Double Slide

- LLDPE (Linear Low-Density Polyethylene) made of self-colored polyethylene plastic material, which is designed to slide from a 100 cm high platform is produced in a single piece and double-walled form with a minimum weight of 40 kg.
- It is manufactured in such a way that the inner height dimension of the side protective corners of the slide is 25 cm, the width of the sliding surface is 42 cm, and the slope is 25-30 degrees.
- A flat slide entrance panel is used to ensure safety at the slide entrance.
- In order for the product surface to be smooth; Sandblasting is applied to the surface of the mold made of aluminum or its equivalent material, and it is produced by passing the Teflon coating process for surface brightness.
- The slide is fixed to the ground with a metal apparatus from the anchorage point at the bottom of the slide's exit point.

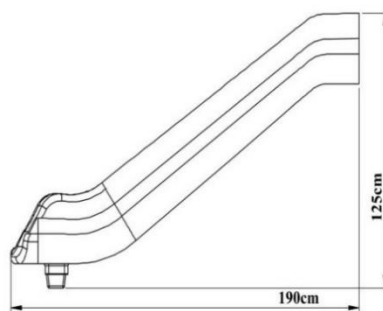
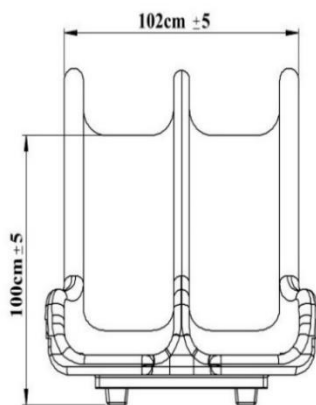

Dimensions	Platform Height	100 cm
	Side Wall Length	25cm
	Slide Inner Width	42 cm
	Slide Length	190 cm
Features	Raw material	LLDPE
	Min. Slide Weight	40 kg

H:150 Spiral Slide

- It is produced from a single piece of polyethylene plastic material with a low-density LLDPE (Linear Low-Density Polyethylene) rotation molding method, which is spirally molded from a 150±10 cm high platform to a minimum Ø89 mm profile pipe in its center, in a self-colored form.
- It is manufactured in such a way that the inside height measure of the side protective corners of the slide is 17 cm, the width of the sliding surface is 40 cm, and the slope is 25-30 degrees.
- In order to ensure safety, metal spiral guardrails are used on both sides of the slide entrance, and a polyethylene entrance barrier with a minimum weight of 8 kg is used on the upper part.
- A 15*15*5 mm diameter flange is welded to the middle part of the slide, and it is fixed to the floor with an SDM pipe with a diameter of 89 mm, a length of 180 cm.

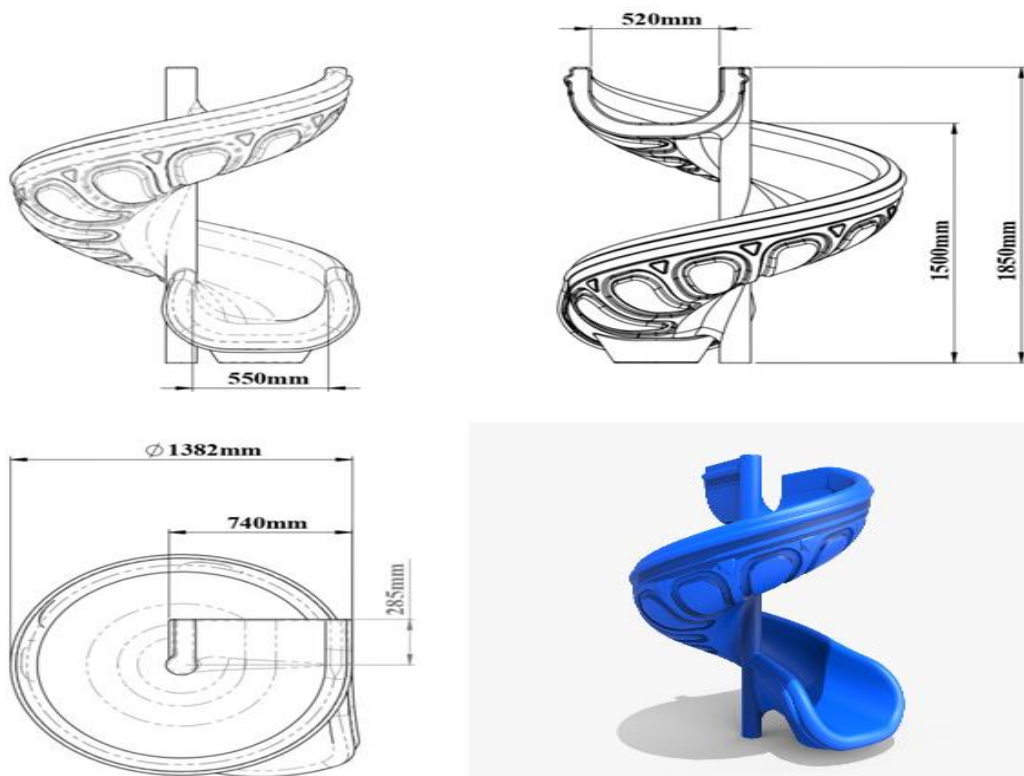

Dimensions	Platform Height	150 cm
	Side Wall Length	17 cm
	Slide Inner Width	40 cm
	Slide Length	185cm
Features	Raw material	LLDPE
	min. Slide Weight	38 kg

H:285 Spiral Slide With Transparent Tube

- H:285 spiral tube slide is designed to slide from the platform ; It consists of 9 pieces, including 1 pcs tube inlet, 1 pcs 110 cm tube, 2 pcs 90 degree tube, 2 pcs 90 degree transparent tube, 1 pcs 80 cm figured tube, 1 pcs 80 cm tube and 1 figured tube outlet. It is manufactured from polyethylene plastic material LLDPE (Linear Low Density Polyethylene) by rotation molding method and self-colored.
- The product produced as disassembled; It is made a whole by assembling the given tube parts to each other according to the given angles.
- The slide is fixed to the ground with a metal apparatus from the anchorage point at the bottom of the slide's exit point.
- In order for the product surface to be smooth; Sandblasting is applied to the surface of the mold made of aluminum or its equivalent material, and it is produced by passing the Teflon coating process for surface brightness.

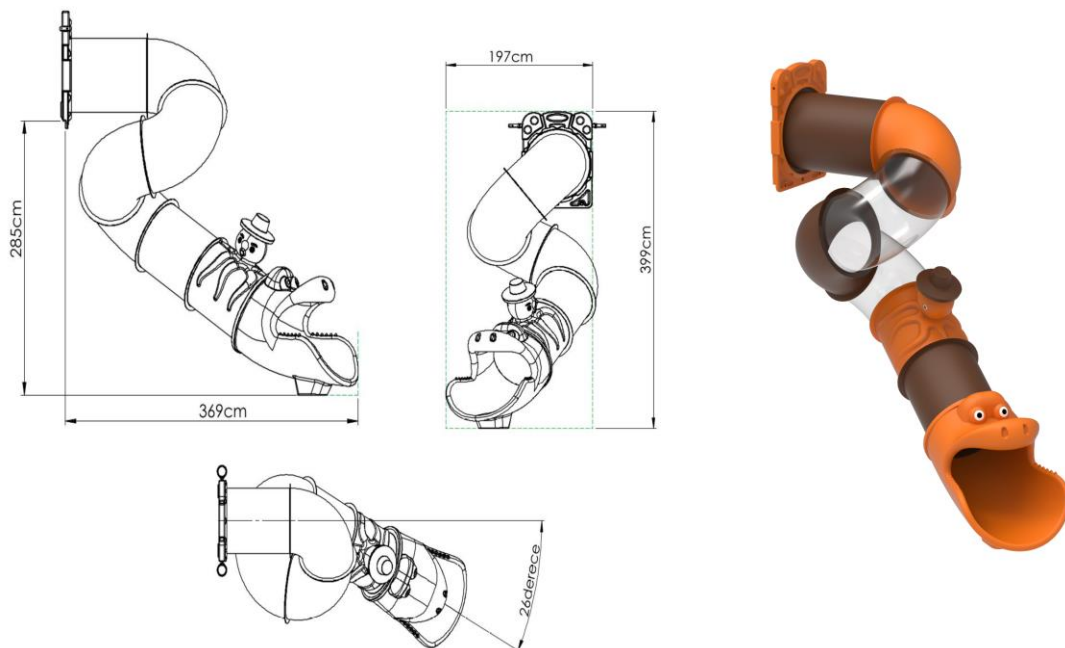

Dimensions	Platform Height	285 cm
	Panel Entry Diameter	75 cm
Features	Raw material	LLDPE
	min. Slide Weight	155 kg

Tube Slide Entry

- It is manufactured from self-colored polyethylene plastic material as a one-piece and double-walled by rotation molding method with low density (LLDPE Linear Low-Density Polyethylene) designed to prevent falling into the slide entrances.
- Plastic clamps and vertical mouth connection apparatuses are attached to the Ø 27 mm inner pipe ends attached to the slides, and the Ø 114 mm tower is fixed to the pipes and screwed from the parts of the panels that sit on the platform.
- In order for the product surface to be smooth; It is produced by sandblasting the surface of the mold made of aluminum or its equivalent material and undergoing a Teflon coating process for surface brightness.

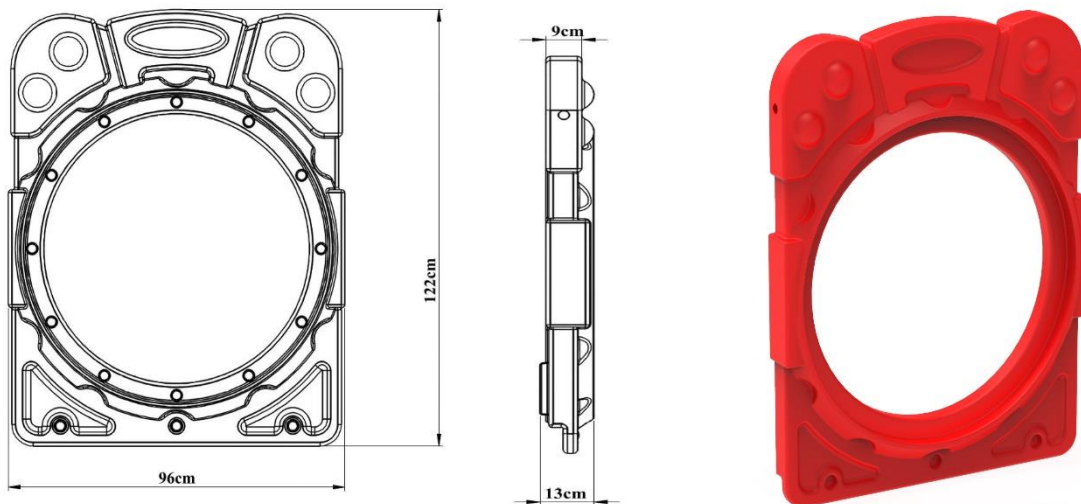

Dimensions	Length	122 cm
	Width	96 cm
	Input Width	75 cm
Features	Min. Weight	9 kg
	Raw material	LLDPE

80 Cm Tube

- The 80 cm tubes forming the tube slides are manufactured as a single piece from self-colored polyethylene plastic material, LLDPE (Linear Low Density Polyethylene) rotation molding method.
- Installation of the product is provided by screwing method.
- In order for the product surface to be smooth; Sandblasting is applied to the surface of the mold made of aluminum or its equivalent material, and it is produced by passing the Teflon coating process for surface brightness.

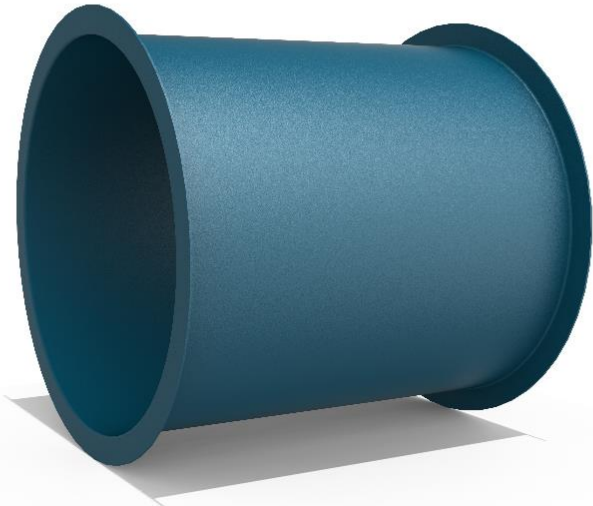
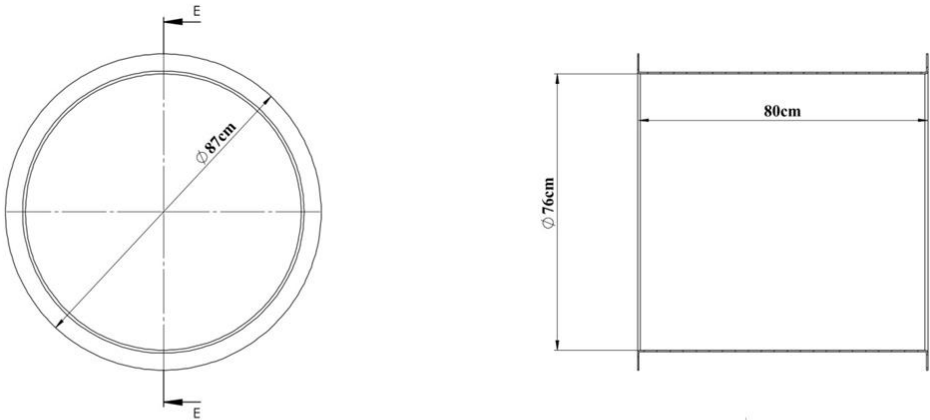

Dimensions	Tube Length	80 cm
	Tube Diameter	87 cm
Features	Minimum Weight	15 kg
	Raw materials	LLDPE

Figured 80 Cm Tube

- 80 cm figured tubes forming tube slides are manufactured as a single piece from self-colored polyethylene plastic material, LLDPE (Linear Low Density Polyethylene) rotation molding method.
- Installation of the product is provided by screwing method.
- In order for the product surface to be smooth; Sandblasting is applied to the surface of the mold made of aluminum or its equivalent material, and it is produced by passing the Teflon coating process for surface brightness.

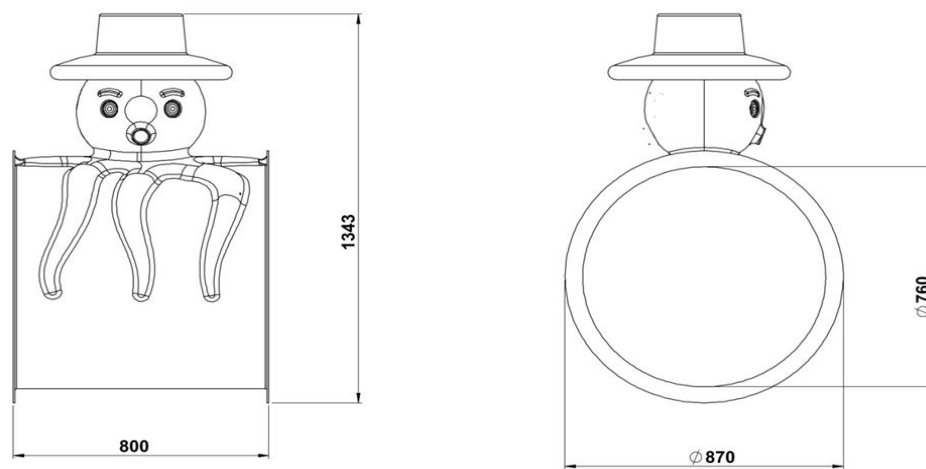

Dimensions	Tube Length	80 cm
	Tube Diameter	87 cm
Features	Minimum Weight	19 kg
	Raw materials	LLDPE

110 Cm Tube

- The 110 cm tubes forming the tube slides are manufactured as a single piece from self-colored polyethylene plastic material, LLDPE (Linear Low Density Polyethylene) rotation molding method.
- Installation of the product is provided by screwing method.
- In order for the product surface to be smooth; sandblasting is applied to the surface of the mold made of aluminum or its equivalent material, and it is produced by passing the Teflon coating process for surface brightness.

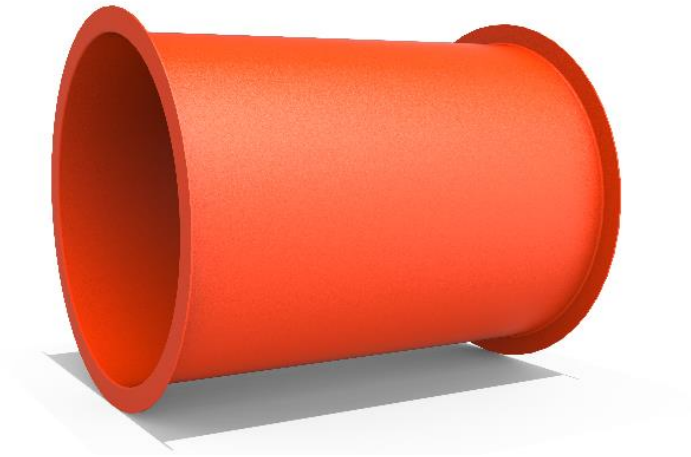
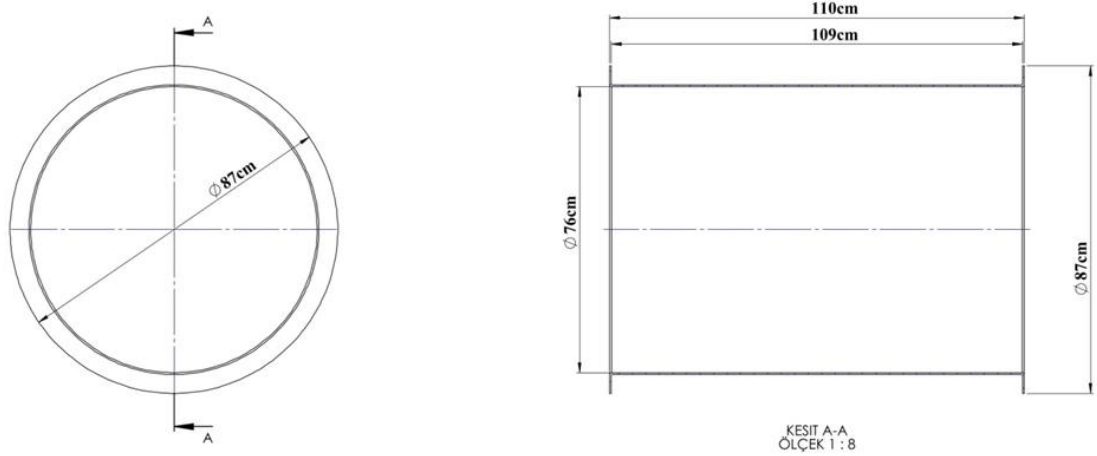

Dimensions	Tube Length	110 cm
	Tube Diameter	87 cm
Features	Minimum Weight	19 kg
	Raw materials	LLDPE

35° Tube

- The 35° tubes that make up the tube slides are manufactured from self-colored polyethylene plastic material, LLDPE (Linear Low Density Polyethylene) by rotation molding method as a single piece, providing an inclination of 35 degrees.
- Installation of the product is provided by screwing method.
- In order for the product surface to be smooth; Sandblasting is applied to the surface of the mold made of aluminum or its equivalent material, and it is produced by passing the Teflon coating process for surface brightness.

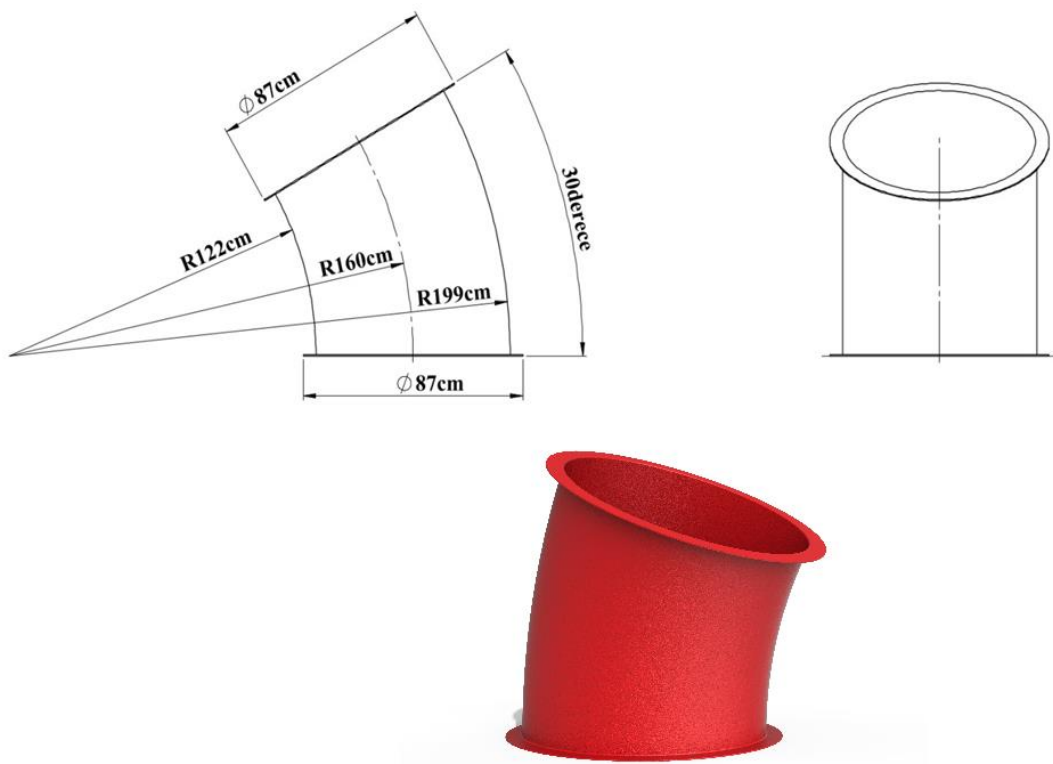

Dimensions	Tube Angle	35°
	Tube Diameter	87 cm
Features	Minimum Weight	17 kg
	Raw materials	LLDPE

90° Tube

- The 90° tubes that make up the tube slides are manufactured from self-colored polyethylene plastic material, LLDPE (Linear Low Density Polyethylene) by rotation molding method as a single piece, providing an inclination of 90 degrees.
- Installation of the product is provided by screwing method.
- In order for the product surface to be smooth; Sandblasting is applied to the surface of the mold made of aluminum or its equivalent material, and it is produced by passing the Teflon coating process for surface brightness.

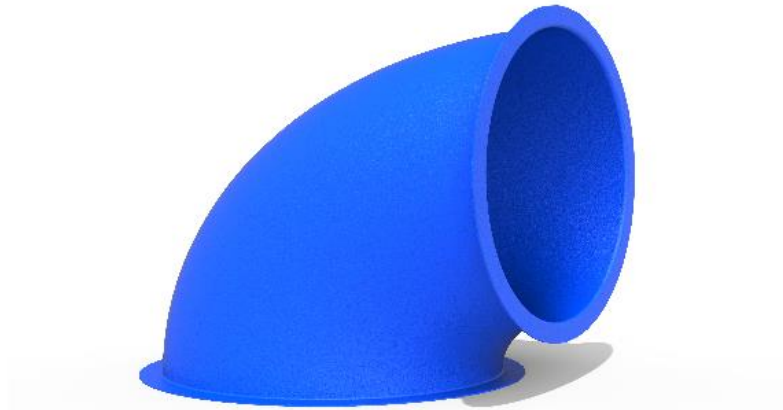
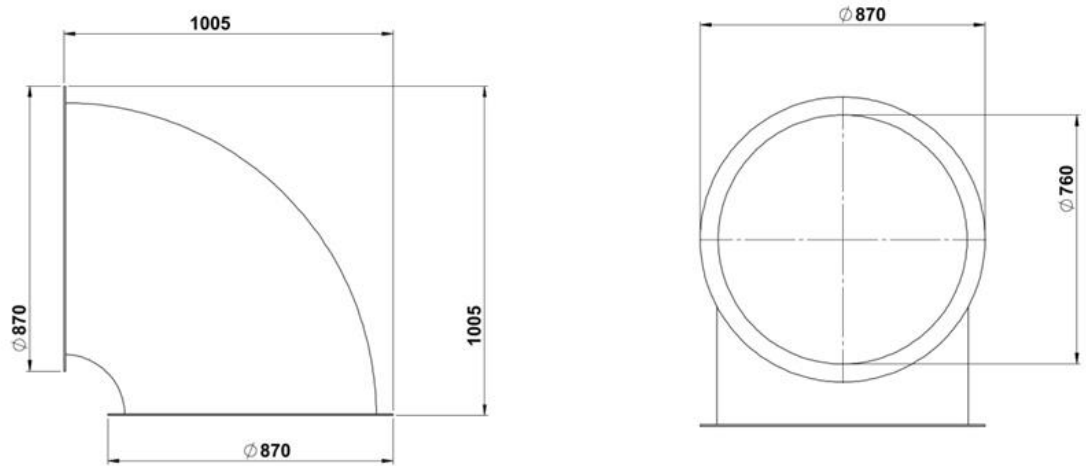

Dimensions	Tube Angle	105 cm
	Tube Diameter	87 cm
Features	Minimum Weight	19 kg
	Raw materials	LLDPE

90° Transparent Tube

- The 90° transparent tubes forming the tube slides will be made of 6 mm thick transparent acrylic plexiglass material.
- Installation of the product is provided by screwing method.

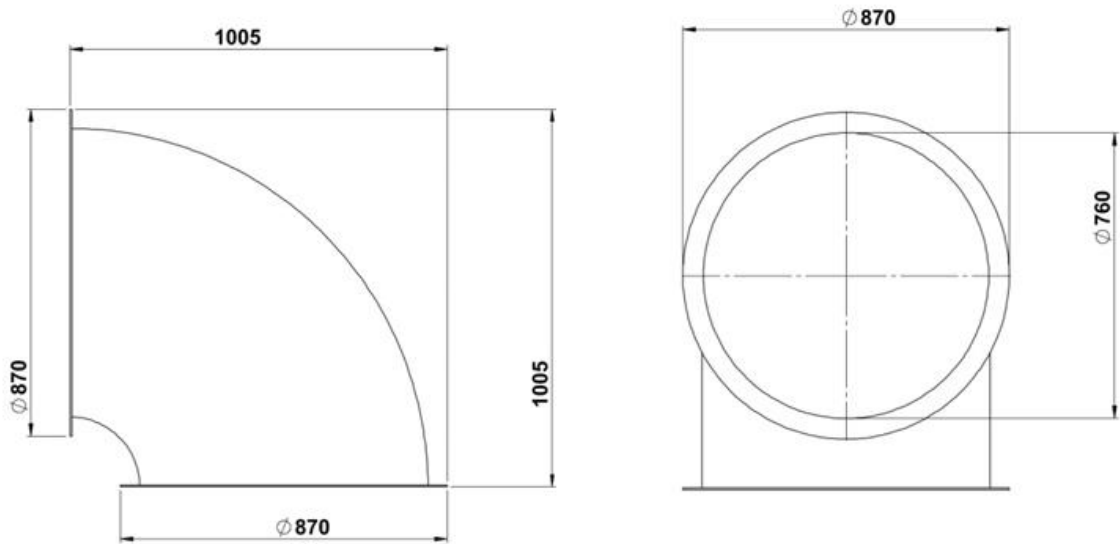

Dimensions	Tube Angle	110 cm
	Tube Diameter	87 cm
Features	Minimum Weight	15±5 kg
	Raw materials	Plexiglass

Tube Output

- The tube outlet forming the tube slides is manufactured as a single piece by rotation molding method from self-colored polyethylene plastic material, LLDPE (Linear Low Density Polyethylene) so that the child can come out of the play element safely.
- Installation of the product is provided by screwing method.
- In order for the product surface to be smooth; Sandblasting is applied to the surface of the mold made of aluminum or its equivalent material, and it is produced by passing the Teflon coating process for surface brightness.

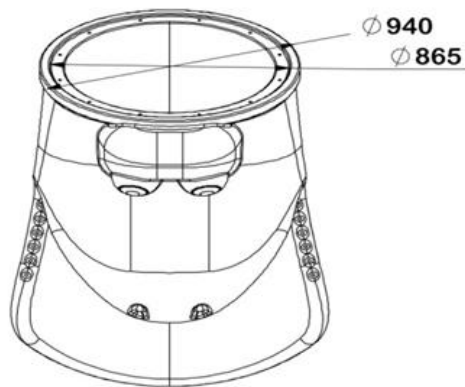
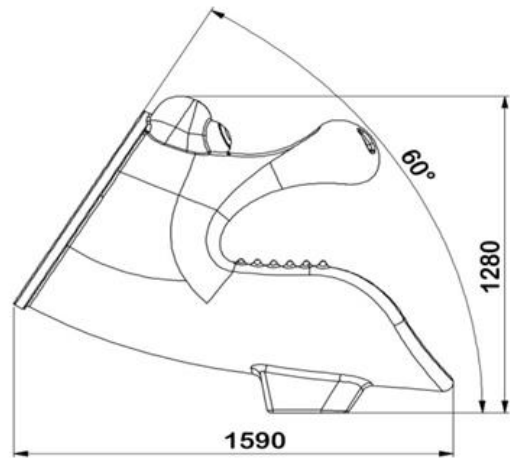
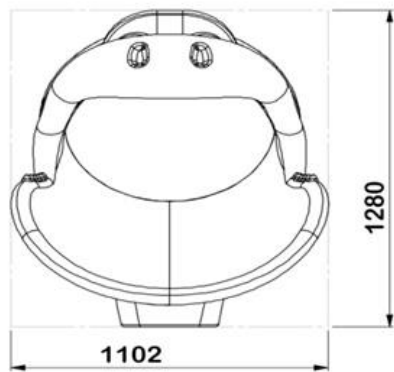

Dimensions	Tube Output Length	160 cm
	Tube Outlet Diameter	86 cm
Features	Minimum Weight	25 kg
	Raw materials	LLDPE

House Roof

- The house roof is manufactured from polyethylene plastic material, LLDPE (Linear Low-Density Polyethylene) with a minimum height of 89 cm, by rotation molding method, in two parts as body and upper apparatus, in self-color.
- In accordance with TS EN 1176-1, when measuring on the platform, the height between the platform and the roof is at least 1800 mm.
- The ideal roof is manufactured to be directly connected to the main construction.
- No connecting element is used in between.
- The roof of the house is completed by mounting 2 large figures on the side surfaces with screws.

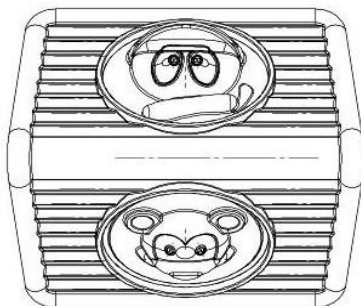
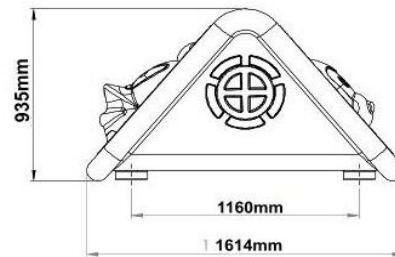
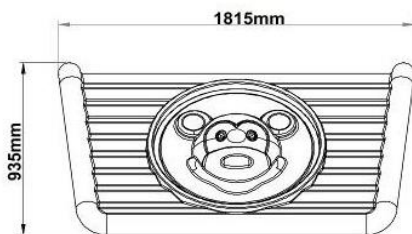

Dimensions	Length	161 cm
	Width	181 cm
	Min. Home Roof Height	89 cm
Features	Min. Home Roof Weight	37 kg
	Raw material	LLDPE

Conical Roof

- The conical is manufactured from polyethylene plastic material, LLDPE (Linear Low-Density Polyethylene) with a minimum height of 94 cm, by rotation molding method, in two parts as body and upper apparatus, in self-color.
- In accordance with TS EN 1176-1, when measuring on the platform, the height between the platform and the roof is at least 1800 mm.
- The conical roof is manufactured to be directly connected to the main construction.
- No connecting element is used in between.
- The apparatus in its four corners are mounted with screws.
- Its upper apparatus is mounted on the roof body with an imbus screw system.

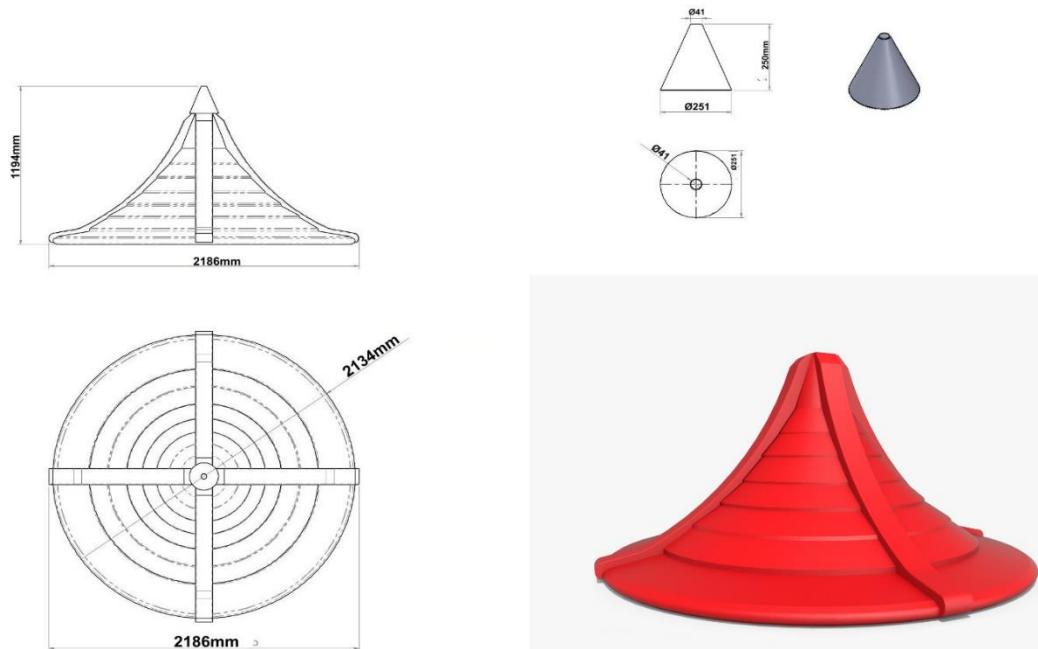

Dimensions	Diameter	185 cm
	Min. Conical Roof Height	94 cm
Features	Min. Conical Roof Weight	30 kg
	Raw material	LLDPE

Rock Climbing and Metal Railing

- Rock climbing, is made in aluminium patterns.
- There are hollows on the surface of rock climbing in order to provide function.
- It is designed to ease climbing and helps to improve climbing skills of user group thanks to it's rock shape.
- The product is made of Ø27 pipes.
- In order to make them resistant to corrosion All metal parts used on the product are subjected to polyester-based electrostatic powder paint coating process and are baked in a 200°C oven for 20 minutes.
- Plastic parts are produced from self-colored polyethylene plastic material with LLDPE (Linear Low Density Polyethylene) rotation molding method, with a double wall of 4-6mm thickness.
- Plastic parts are designed to be suitable for indoor and outdoor use, resistant to UV lights and not harming the user.
- It is mounted on the platform with the help of galvanized bolts and nuts from the bottom.

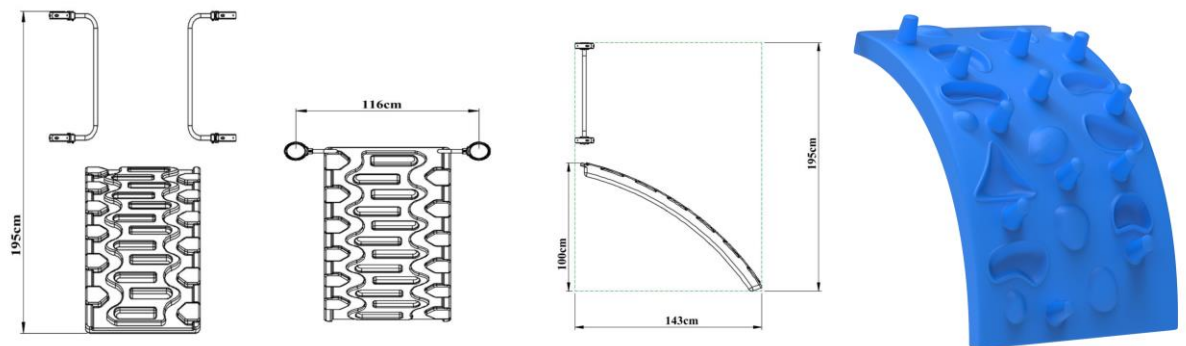

Dimensions	Rock Climbing Height	195 cm
	Rock Climbing Width	116 cm
	Rock Climbing Length	143 cm
Features	Rock Climbing min Weight	15 kg
	Raw Material	LLDPE

Woodpecker Figure

- The woodpecker figure is used to add visuality to playgroups.
- It is produced from polyethylene material suitable for indoor and outdoor use in accordance with 114 mm pipe.
- It is resistant to UV lights and is designed not to harm the user.
- The woodpecker figure weighs 2 kg.



Ø 114 Hat Plug

- The cap plug is used to close open-ended pipes in children's playgroups, seesaws, swings, and other products.
- The cap plug is manufactured from polyethylene material for indoor and outdoor use.
- The product is resistant to UV lights.
- Its design is oval in a way that does not harm the user.
- It grasps the pipe with its 114 mm double-walled inlet and is easy to install.

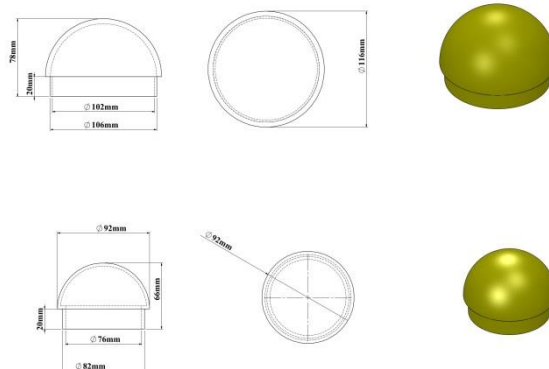

Ø 114 Anchor Cover

- Anchor caps measuring 114 mm are used to cover open-ended pipes in children's playgrounds, seesaws, swings, and other products.
- Anchor caps are produced from polythene plastic material for indoor and outdoor use.
- It is resistant to UV lights and is designed not to harm the user.
- It is manufactured as double-walled and assembled with a screwing system.

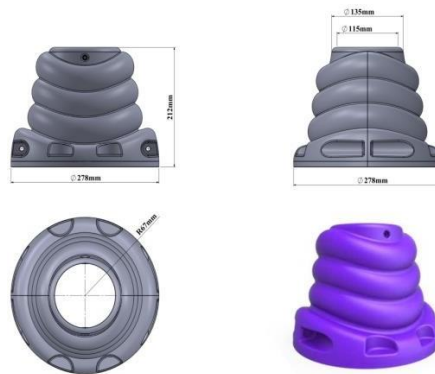

Screw Concealment

- Screw hides are used in all playgroups to prevent possible accidents and injuries.
- Screw hides; It provides an aesthetic appearance to playgroups and parking elements by allowing mounting elements such as screws and nuts to be hidden.
- Screw closures are produced from polythene plastic material by injection method, suitable for indoor and outdoor use.
- It is resistant to UV lights and is designed not to harm the user.

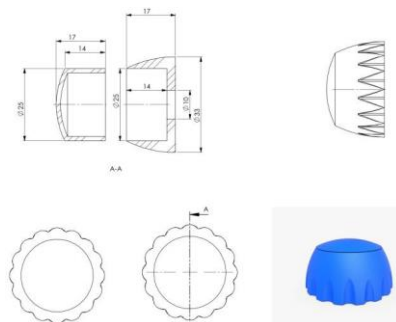

Connectors

Ø 114 Plastic Clamps

- Plastic clamps, board on the playgroup, slide entrance, railings, etc. It enables the elements to be mounted on the carrier system with a diameter of 114 mm.
- Clamps are manufactured from fibrous polyamide raw material by injection method.
- The clamp is designed in accordance with the inner diameter 114 mm pipe.
- It does not rotate on the pipe surface when tightened.
- After the clamp is connected, there are no protrusions or sharp corners that may cause injury in any part of the clamp.
- It can be produced in the desired color.

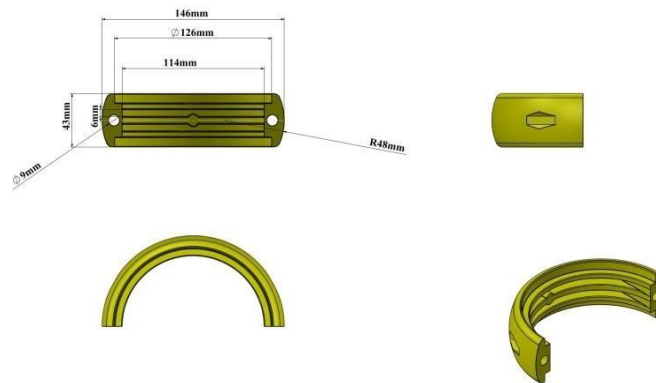

Ø114 Perpendicular Mouth

- Upright mouth, curved mouth, and platform wedge apparatus are used in the assembly of various playgrounds and sports equipment.
- It is produced from polyethylene material suitable for 114 mm pipe, suitable for indoor and outdoor use.
- The product is resistant to UV lights.
- Its design is in a structure that will not harm the user.
- It can be produced in desired colors.

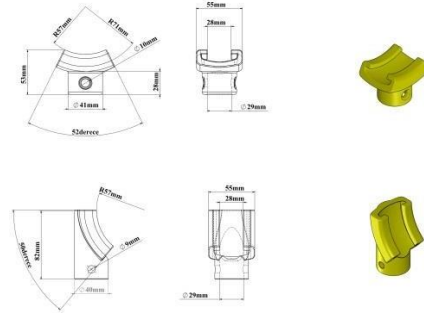

Bolts, Nuts and Washers

- The fasteners (bolts, washers, and nuts) used in-game systems are produced as GeometB321 Plus or galvanized coating to protect them against corrosion.
- There are no nut and bolt protrusions anywhere in the playset.
- Except for the camber head nut within the playgroup, all nuts are produced with fiber.

